

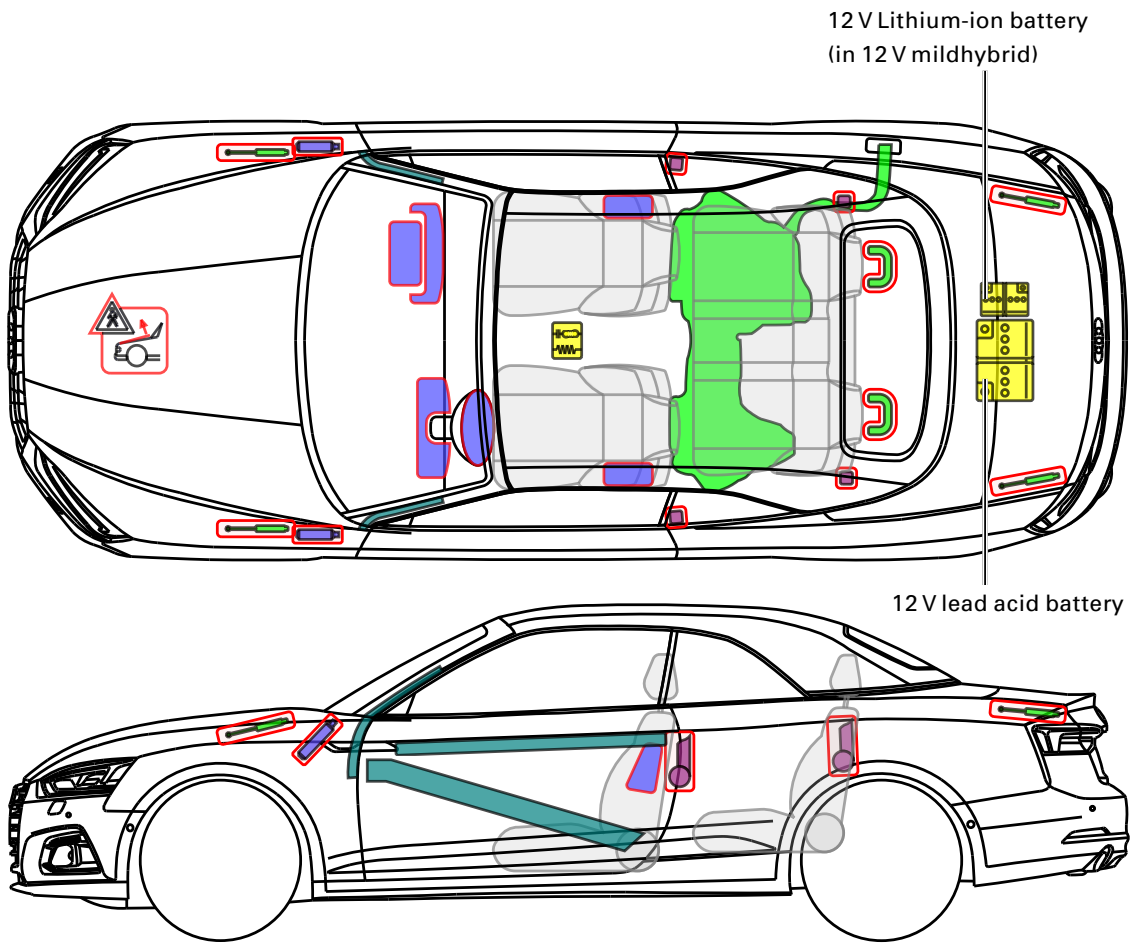

▶ Audi A5 / S5 Cabriolet

from 2017



Legend

	Airbag		Reinforcement		SRS control unit		Pedestrian protection system
	Stored gas inflator		Automatic roll bar		12 V / 48 V Battery		
	Seatbelt pretensioner		Cylinder		Fuel tank		





## ▶ Audi A5 / S5 Cabriolet 12 V Mildhybrid

from 2017

### 12 V lead acid battery and 12 V Lithium-ion battery

 **12 V on-board Lithium-ion battery is automatically deactivated during accidents in which the airbag(s) deployed.**

For all other cases, in order to deactivate the on-board power supply the 12 V Lithium-ion battery has to be separately disconnected in addition to the 12 V lead acid battery. Therefore:

1. remove the cargo floor from the trunk
2. remove the spare tire and vehicle tool kit
3. remove the battery bar
4. separate the minus pole of the 12 V lead acid battery
5. separate the minus pole of the 12 V Lithium-ion battery

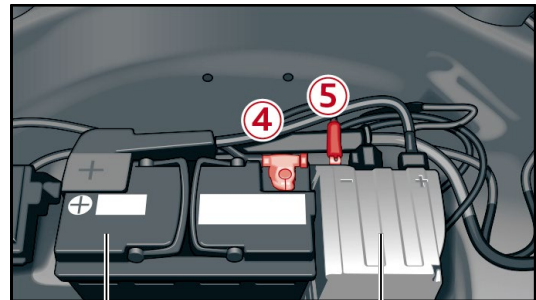
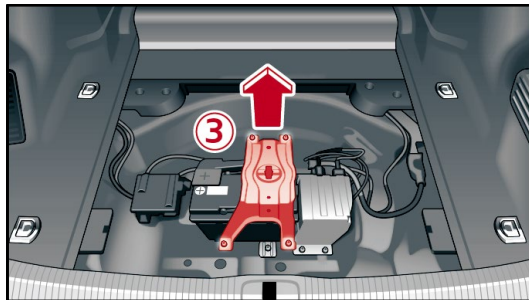
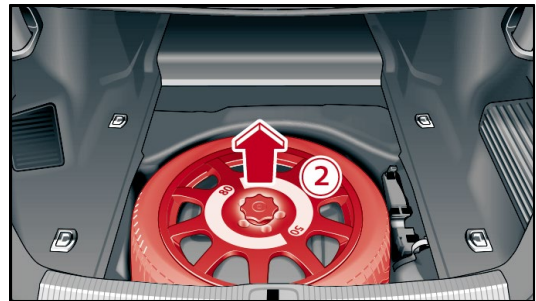

12 V lead battery

12 V Lithium-ion battery