

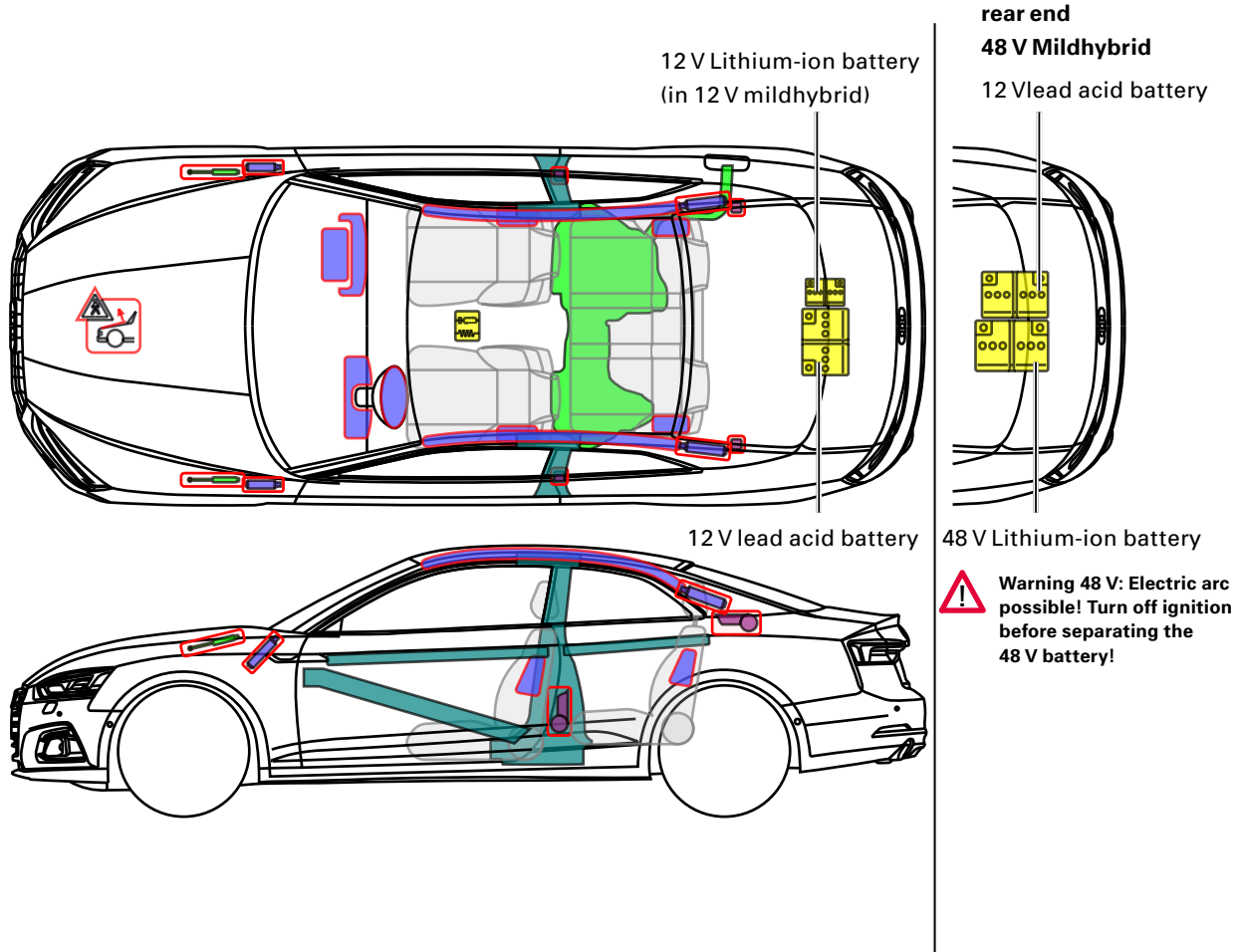

▶ Audi A5 / S5 / RS5 Coupé

from 2016



Legend

	Airbag		Reinforcement		SRS control unit		Pedestrian protection system
	Stored gas inflator		Automatic roll bar		12 V / 48 V Battery		
	Seatbelt pretensioner		Cylinder		Fuel tank		





## ▶ Audi A5 / Coupé 12 V Mildhybrid

from 2016

### 12 V lead acid battery and 12 V Lithium-ion battery

**⚠ 12 V on-board Lithium-ion battery is automatically deactivated during accidents in which the airbag(s) deployed.**

For all other cases, in order to deactivate the on-board power supply the 12 V Lithium-ion battery has to be separately disconnected in addition to the 12 V lead acid battery. Therefore:

1. remove the cargo floor from the trunk
2. remove the spare tire and vehicle tool kit
3. remove the battery bar
4. separate the minus pole of the 12 V lead acid battery
5. separate the minus pole of the 12 V Lithium-ion battery

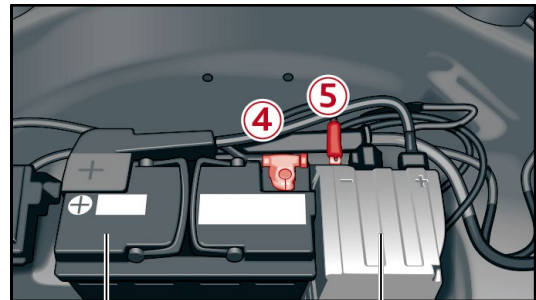
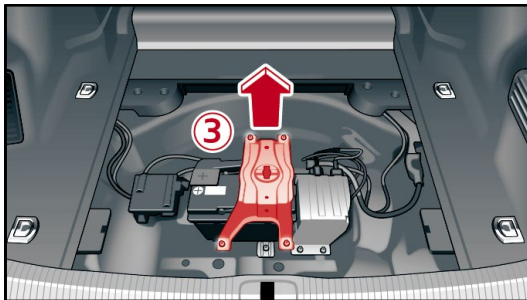
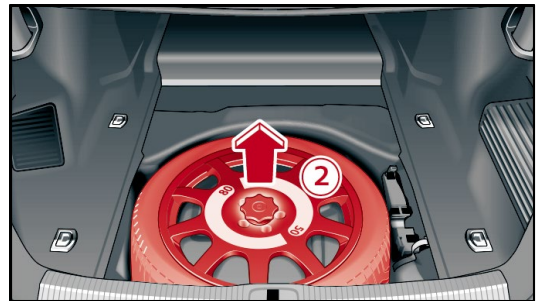

12 V lead battery

12 V Lithium-ion battery



## ▶ Audi A5 / S5 Coupé 48 V Mildhybrid

from 2020

### 12 V lead acid battery and 48 V Lithium-Ion battery

**⚠ 48 V on-board Lithium-Ion battery is automatically deactivated during accidents in which the airbag(s) deployed.**

For all other cases, in order to deactivate the on-board power supply the 48 V Lithium-Ion battery has to be separately disconnected in addition to the 12 V lead acid battery. Therefore:

**⚠ WARNING! Hazard due to electric arc at 48 V**

**⚠ Turn off ignition before separating the 48V battery!**

For minimization the risc of electric arc it is recommended to disconnect the batteries as follows:

1. Remove the cargo floor from the trunk
2. Localize the batteries
3. Separate the minus pole of the 12 V lead acid battery
4. Pull out the communication connector plug of the 48 V Lithium-Ion-battery
5. Separate the minus pole of the 48 V Lithium-Ion battery

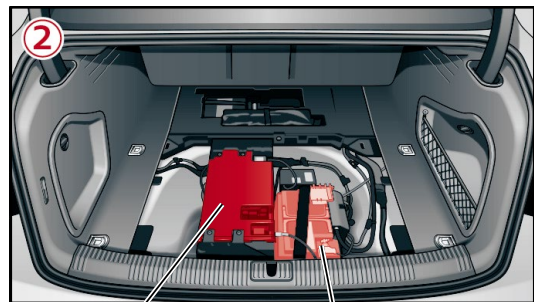
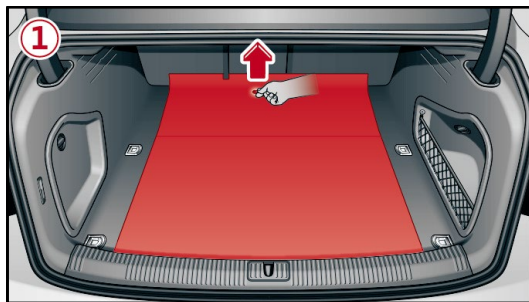

48 V Lithium-Ion battery

12 V lead acid battery

