



# Audi Q8/SQ8 e-tron

SUV inkl. Sportback, fr.o.m. 2023



endast högerstyrda bilar

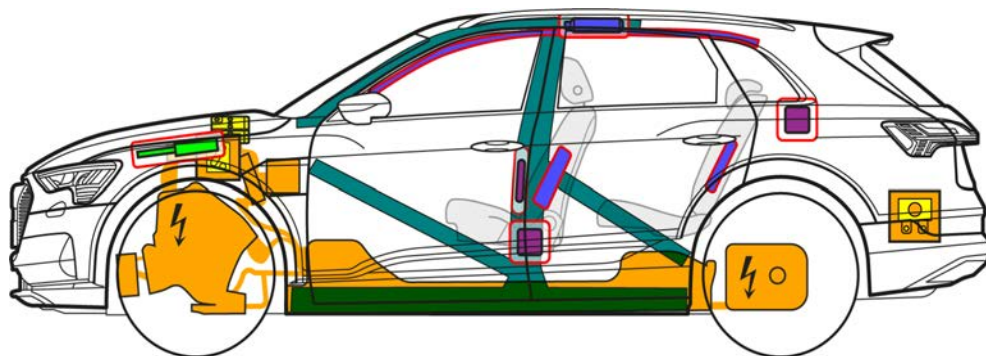
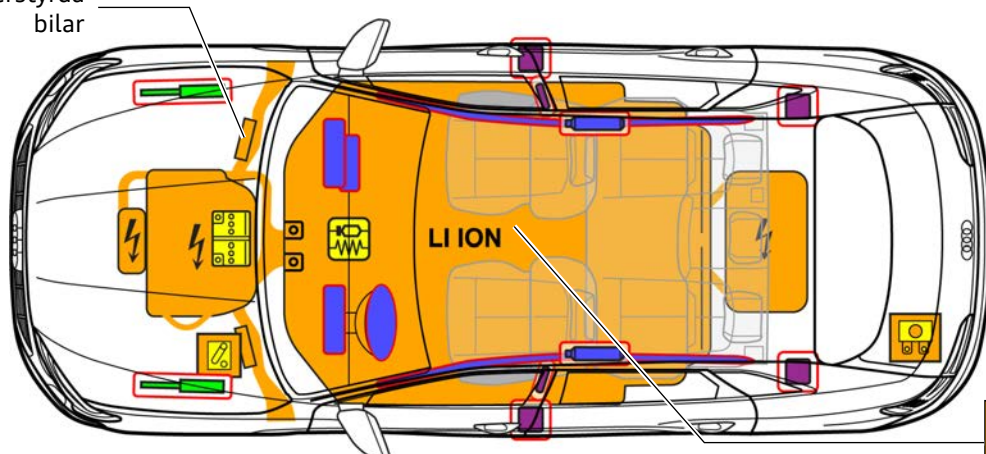

|  |  |  |                         |  |                     |  |                     |  |  |
|--|--|--|-------------------------|--|---------------------|--|---------------------|--|--|
|  | Airbag   |  | Gasgenerator            |  | Bältessträckare     |  | SRS styrdon         |  | Gastrycksdämpare/förspänd fjäder               |
|  | Höghållfasta områden                                       |  | Lågspänningsbatteri     |  | Högspänningsbatteri |  | Högspänningsledning |  | Lågspänningsenhet som kopplar bort högspänning |
|  | Säkringsdosa, avaktivering högspänningssystem till lågvolt |  | Högspänningskomponenter |  |                     |  |                     |  |  |



# Audi Q8/SQ8 e-tron

SUV inkl. Sportback, fr.o.m. 2023

## 1. Identifiering/igenkänning



Elmotorn är ljudlös. Indikeringen i kombiinstrumentet (Powermeter) meddelar om eldriften är avstängd "OFF" eller driftklar "READY".

Laddanslutning



Modellbeteckning  
(modellbeteckningar kan väljas bort)



Q8



Q8 e-tron



Q8 e-tron  
Sportback

## 2. Fastsättning/stabilisering/lyftning

Immobilisera fordon

Tryck på parkeringsknappen "P" och aktivera handbromsen.



Lyftpunkter

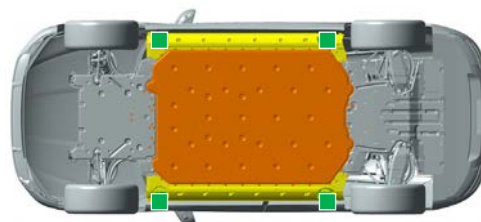

lämpliga lyftpunkter

högspänningsbatteri

Slå av tändningen (Powermeter-indikering "OFF")



Tryck på knappen START-STOP, utan att trampa ner bromspedalen

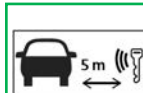

Istället för en bilnyckel kan även ett nyckelkort eller en mobilapp användas.

## 3. Åtgärda direkta faror/säkerhetsbestämmelser

Vid olyckor då krockkuddar löses ut avaktiveras högspänningssystemet automatiskt omedelbart efter krockkuddsaktivering. Högspänningssystemet är spänningsfritt ca 20 sek. efter avaktiveringen.



Berör, öppna eller skär inte i skadade högspänningskomponenter, högspänningsledningar eller högspänningsbatteri! Bär lämplig skyddsutrustning!

I alla andra fall kan högspänningssystemet avaktiveras enligt följande:

Alternativ 1: från motorrummet

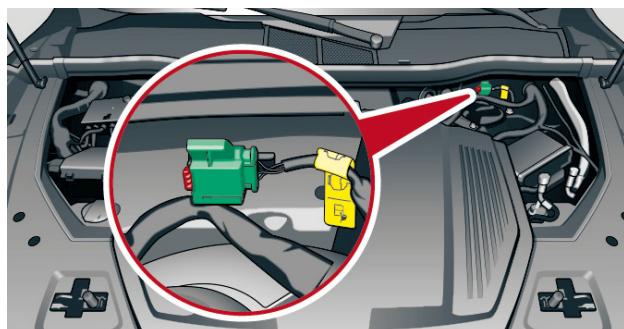

① Dra ut den röda fliken

② Dra ur den svarta kontakten





# Audi Q8/SQ8 e-tron

SUV inkl. Sportback, fr.o.m. 2023



## Alternativ 2: (säkring i bagageutrymmet)

Lyft upp golvet

Ta av kåpan

Dra ut säkringen

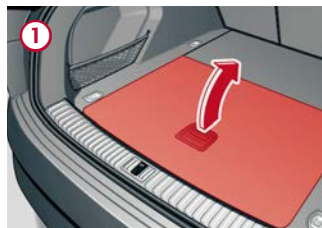

## Frånkoppla 12 V-batteriet

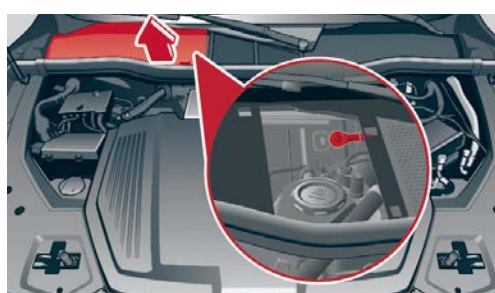

12 V-batteriet sitter sig i framvagnen under vattenavrinningslådans lock.

Batteriets jordkabel är fastskruvad med karossen på vattenavrinningslådans framvägg.

Här kan batteriets jordanslutning (minuspole) lossas från karossens kontaktställe.

## Lossa från laddstationen (nödupplåsning laddkontakt)



Ta av skyddet

Dra i den gula öglan

Dra ur laddkontakten

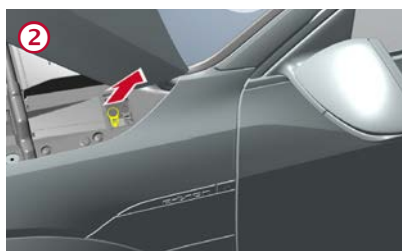
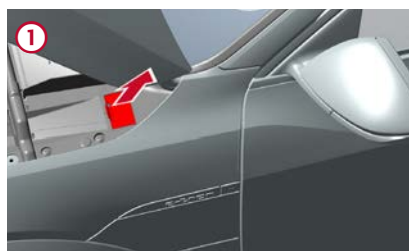

## 4. Åtkomst till passagerare

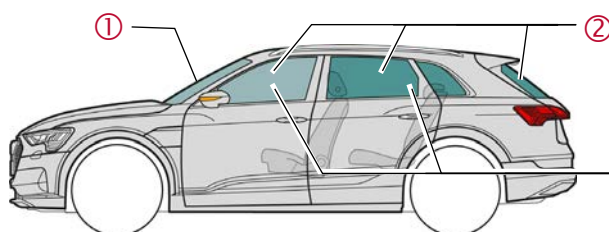

### Typer av glas:

- ① Laminerat säkerhetsglas
- ② Enkelt säkerhetsglas
- ③ Sidorutor som tillval laminerat säkerhetsglas



# Audi Q8/SQ8 e-tron

SUV inkl. Sportback, fr.o.m. 2023

## 5. Lagrad energi/vätskor/gaser/fasta ämnen



12 V



400 V  
litium-jon



Om kylvätska läcker ut från batterikylsystemet föreligger risk för en termisk reaktion i högspänningsbatteriet.  
Övervaka högspänningsbatteriets temperatur!



## 6. Vid brand



Vid skador eller felaktig användning kan litium-jon-batterier självantändas omedelbart eller med tidsfördröjning resp. antändas igen efter brandbekämpningen!  
Bär lämplig skyddsutrustning!



## 7. Under vatten

Avaktivera högspänningssystemet efter bärgning av fordonet ur vattnet (se kapitel 3) och låt vattnet rinna ur. Bär lämplig skyddsutrustning!

## 8. Bärgning/transport/förvaring



Litium-jon-batterier kan självantända eller antändas igen efter brandbekämpningen!  
Bär lämplig skyddsutrustning!



Vid krockade fordon eller vid skadat eller eventuellt skadat högspänningssystemet (se kapitel 3). Parkera fordonet på säkert avstånd (minst 5 m) från byggnader och andra fordon (karantänområde).



Bogsera inte ett olycksdrabbat fordon på drivaxlarna.

## 10. Förklaring av de piktogram som används



brännbart



frätande,  
hudirriterande



hälso-  
vådligt



miljö-  
farligt



Elfordon



Varning  
högspänning



Observera, fara



Släck med  
vatten



Farlig spänning

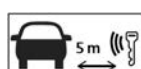

Ta bort smart  
nyckel



Använd  
IR-värmeamera



Lås upp  
motorhuven



Lås upp  
bagageutrymme